



Partsbook

for

Static Pulverizer DSP-60 Extreme

Product	Part Number	Ref.
DSP-60 Extreme Serie 2	DSP60H140BAA5	

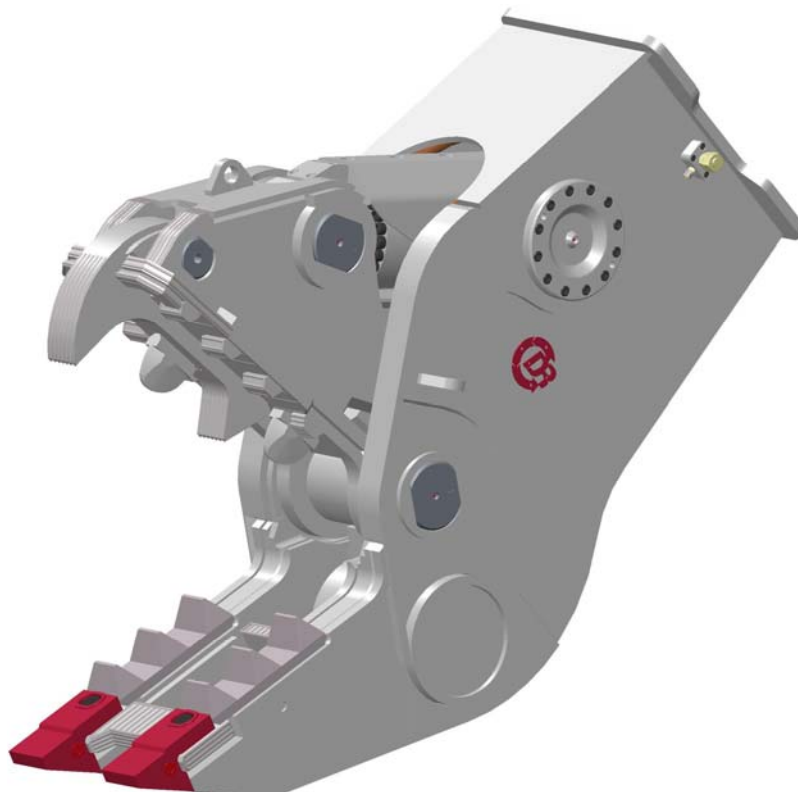

Partsbook_dsp60h140baa5-a.docx

August 2014

Demarec Demolition and Recycling Equipment BV

Den Hoek 10, 5845 EL St. Anthonis, Netherlands

TEL.
FAX

+31 (0) 485 442300
+31 (0) 485 442120

INTERNET
E-MAIL

www.demarec.com
info@demarec.com

Static Pulverizer

Page	1	of	16
Date	August 2014		
Product type	DSP-60 Extreme		
Number	DSP60H140BAA5-A		

Housing GP

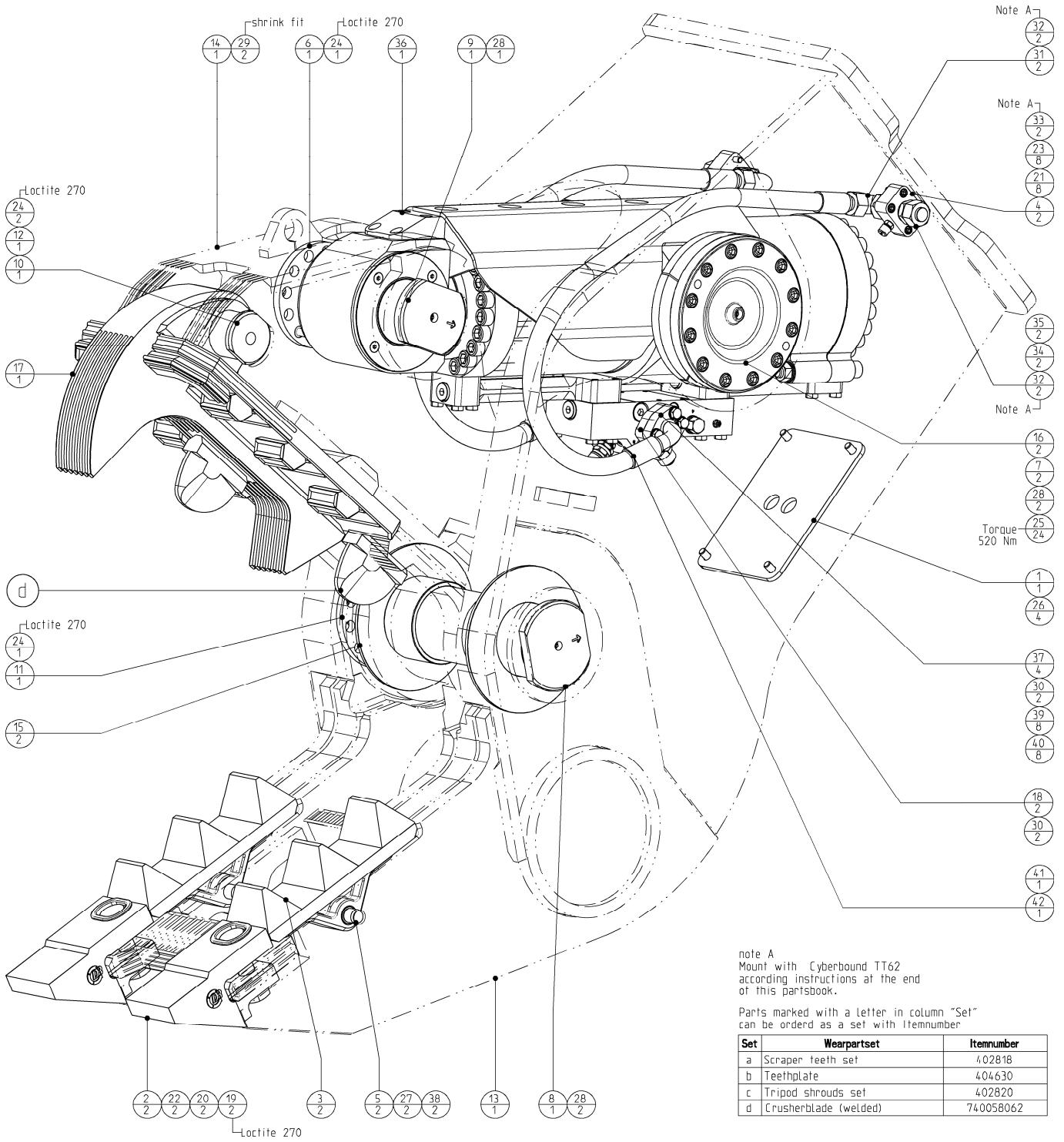

note A
Mount with Cyberbound TT62 according instructions at the end of this partsbook.

Parts marked with a letter in column "Set" can be ordered as a set with Itemnumber

Set	Wearpartset	Itemnumber
a	Scraper teeth set	402818
b	Teethplate	404630
c	Tripod shrouds set	402820
d	Crusherblade (welded)	740058062

<h1>Static Pulverizer</h1>	Page	2	of	16
	Date	August 2014		
	Product type	DSP-60 Extreme		
<h2>Housing GP</h2>	Number	DSP60H140BAA5-A		

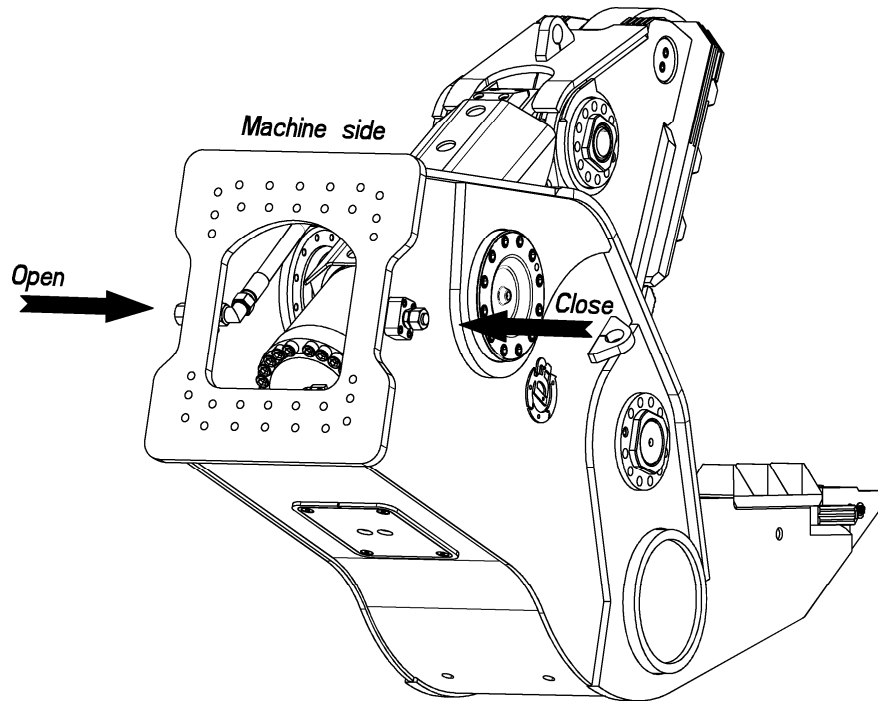

					25	500276	Hex. socket head cap screw	24	
					24	500258	Hex. socket head cap screw	4	
					23	500250	Hex. socket head cap screw	8	
				a	22	500201	Bolts Hexagon	2	
					21	500077	Washer spring	8	
				a	20	500058	Washer HV	2	
				a	19	500009	Nut Hexagon	2	
					18	406073	Flange - intermed. SAE 1 1/4"	2	
	42	505001_RH_RM-DSP60	Hydr. hose asm. 1" SAE 100R13	1	b	17	404630	Teethplate asm.	1
	41	505001_LH_RM-DSP60	Hydr. hose asm. 1" SAE 100R13	1		16	402920	Bearing housing	2
	40	122000163	Washer normal	8		15	402483	Spacer	2
	39	506050	Bolts Hexagon	8		14	401581	Jaw asm. machined	1
c	38	504053	O-ring	2		13	401571	Housing asm. machined	1
	37	503504	SAE split-flange	4		12	401549	Lock - cover	1
	36	501310	Hydraulic Cylinder & Valve GP	1		11	401548	Locknut	1
	35	500948	Blanking plug	2		10	401547	pin	1
	34	500943	Nut coupling	2		9	401546	Pin	1
	33	500740	Test-point	2		8	401545	Pin	1
	32	500698	Male stud coupling	4		7	401544	Ring	2
	31	500676	Adjustable male stud elbow	2		6	401312	Locknut	1
	30	500603	O-ring	4	c	5	401311	Lock - pin	2
	29	500574	Bushing	2		4	401200	Flange	2
	28	500560	Grease - nipple	5	c	3	401194	Shroud - tripod	2
c	27	500559	Tension bush - outside	2	a	2	401193	Tooth - scraper	2
	26	500358	Flat countersunk head cap screws	4		1	400673	Cover	1
					Set	POS	PARTNUMBER	PARTNAME	QT

Static Pulverizer

Page	3	of	16
Date	August 2014		
Product type	DSP-60 Extreme		
Number	501310-00		

Cylinder & Valve GP

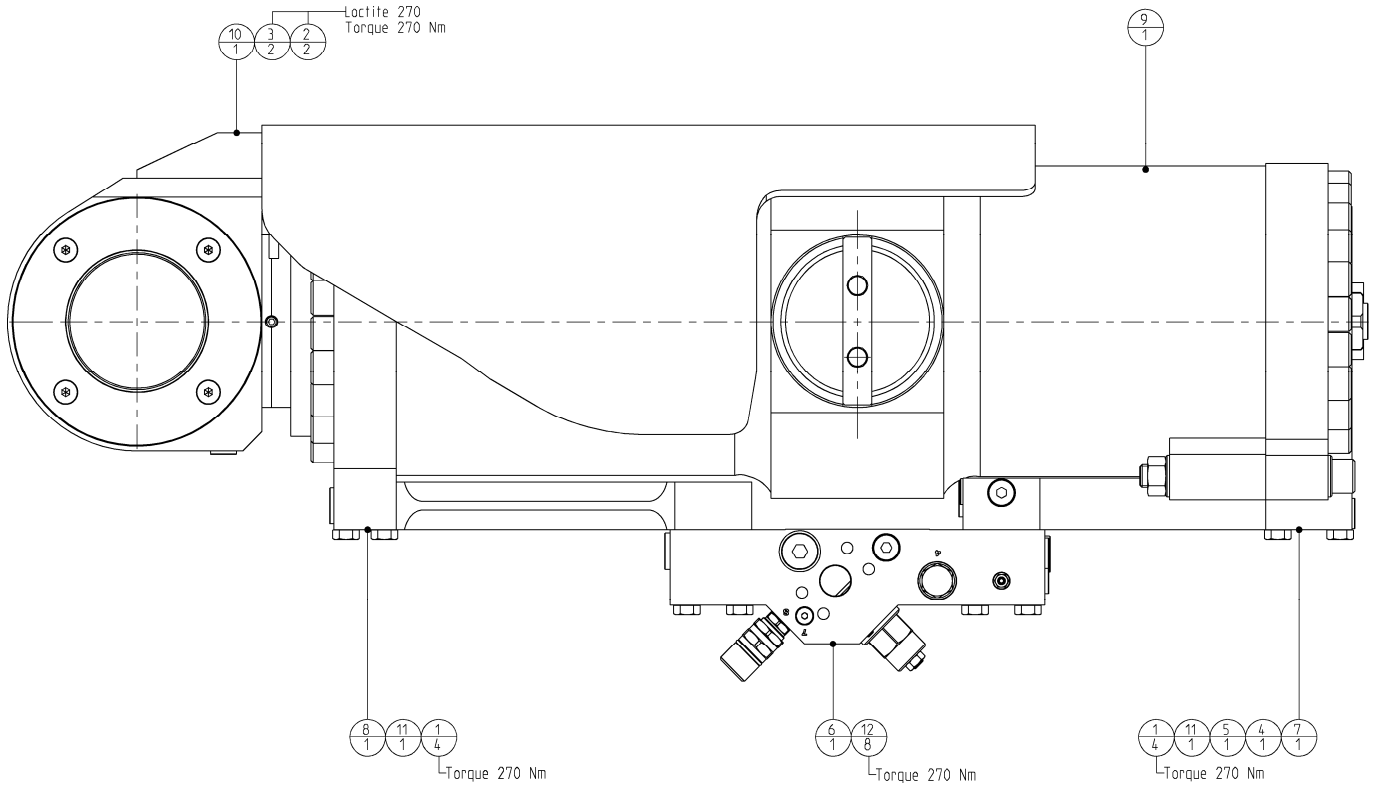

12	120013886	Bolts Hexagon	8
11	504009	O-ring	2
10	502746	Protection cap asm.	1
9	502736	Hydraulic Cylinder GP	1
8	502407	Flange - rod GP	1
7	502406	Flange - bottom GP	1
6	501240	Valve GP DemaPower 2.0	1
5	500601	O-ring	1
4	500600	O-ring	1
3	500265	Hex. socket head cap screw	2
2	500262	Hex. socket head cap screw	2
1	500150	Bolts Hexagon	8
POS	PARTNUMBER	PARTNAME	QT

Static Pulverizer

Page	4	of	16
Date	August 2014		
Product type	DSP-60 Extreme		
Number	502736-02		

Cylinder GP

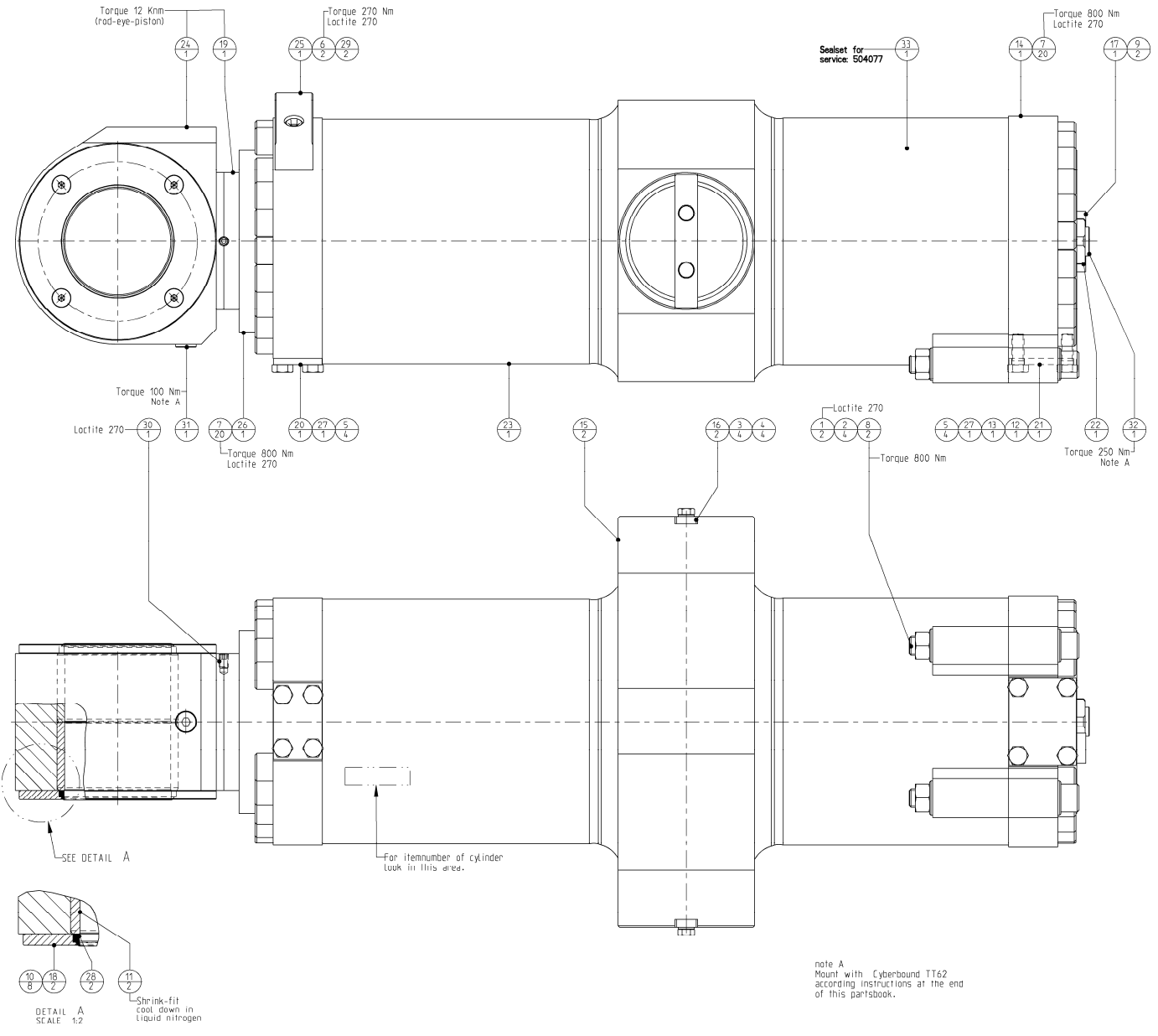

Static Pulverizer	<i>Page</i>	5	<i>of</i>	16
	<i>Date</i>	August 2014		
	<i>Product type</i>	DSP-60 Extreme		
Cylinder GP	<i>Number</i>	502736-02		

33	502373_RM502736	Seal - set	1
32	290058186	Blanking end ISO 6149	1
31	290058184	Blanking end ISO 6149	1
30	120000402	Hex. socket set screw	1
29	506033	Lockwasher - Schnorr	2
28	504022	Scraper	2
27	504009	O-ring	2
26	502751	Cylinder - head	1
25	502745	Support - protection cap	1
24	502741	Rod - eye	1
23	502737	Cylinder - house asm.	1
22	502405	Bolt - banjo	1
21	502256	Blanking cover	1
20	502255	Blanking cover	1
19	502222	Rod - tube	1
18	502128	Spacer	2
17	502112	Lockplate	1
16	502070	Lockplate	2
15	502069	Bearing	2
14	501311	Bottom asm.	1
13	500601	O-ring	1
12	500600	O-ring	1
11	500573	Bushing	2
10	500347	Flat countersunk head cap screws	8
9	500333	Flat countersunk head cap screws	2
8	500291	Hex. socket head cap screw	2
7	500287	Hex. socket head cap screw	40
6	500260	Hex. socket head cap screw	2
5	500144	Bolts Hexagon	8
4	500133	Bolts Hexagon	4
3	500068	Washer spring	4
2	500056	Washer HV	4
1	500007	Nut Hexagon	2
POS	PARTNUMBER	PARTNAME	QT

Static Pulverizer	Page	6	of	16
	Date	August 2014		
	Product type	DSP-60 Extreme		
Flange GP bottom	Number	502406-02		

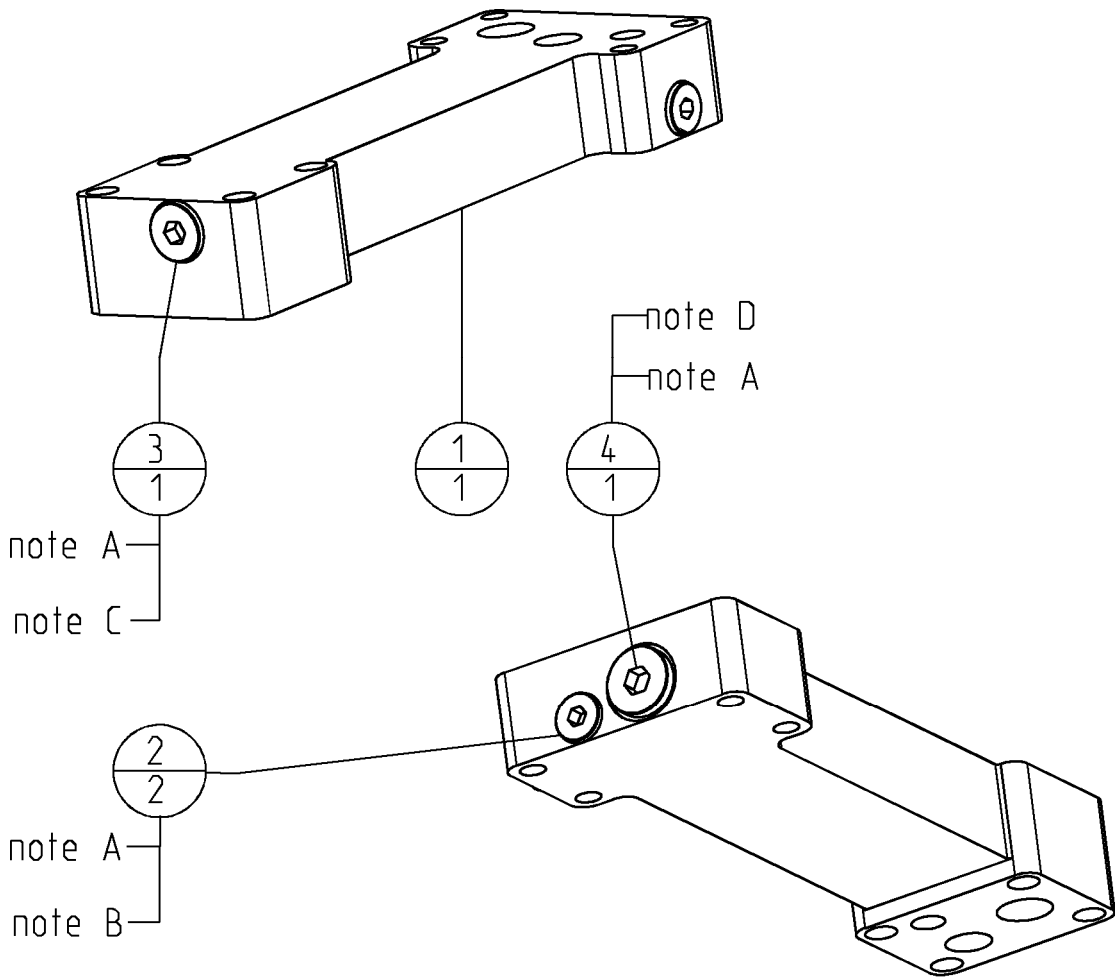

note A: Mount with Cyberbound TT62 according instructions at the end of this partsbook.

note B: Torque 100 Nm

note C: Torque 150 Nm

note D: Torque 250 Nm

4	290058186	Blanking end ISO 6149	1
3	290058185	Blanking end ISO 6149	1
2	290058184	Blanking end ISO 6149	2
1	502099	Flang - bottom	1
POS	PARTNUMBER	PARTNAME	QT

Static Pulverizer	Page	7	of	16
	Date	August 2014		
	Product type	DSP-60 Extreme		
Flange GP rod	Number	502407-02		

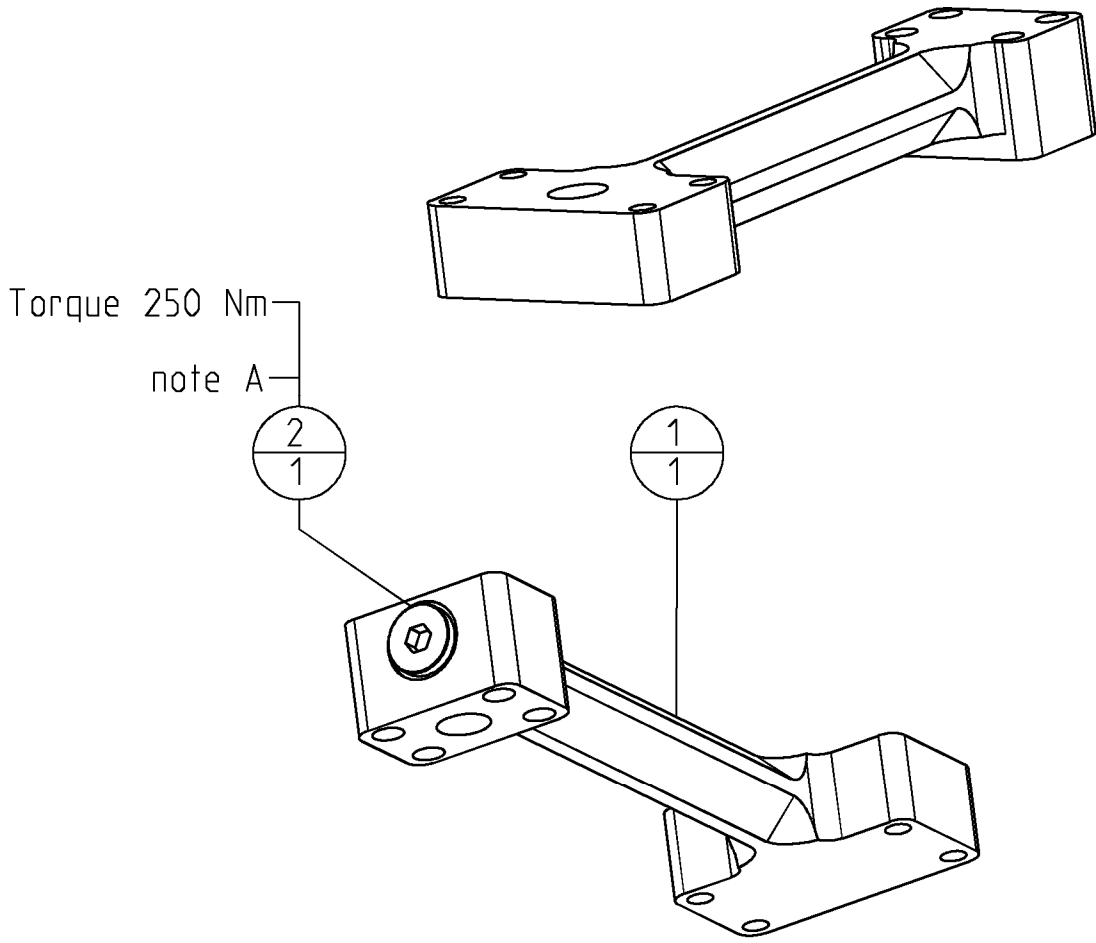

note A
 Mount with Cyberbound TT62
 according instructions at the end
 of this partsbook.

2	290058186	Blanking end ISO 6149	1
1	502100	Flange - rod	1
POS	PARTNUMBER	PARTNAME	QT

Static Pulverizer	<i>Page</i>	9	of	16
	<i>Date</i>	August 2014		
	<i>Product type</i>	DSP-60 Extreme		
Valve GP	<i>Number</i>	501240-00		

19	290058186	Blanking end ISO 6149	3
18	290058185	Blanking end ISO 6149	1
17	290058184	Blanking end ISO 6149	2
16	121067231	Nut Hexagon sealing	2
15	504009	Quad-ring	2
14	502117	Valve - check	1
13	501378	Valve - check	1
12	501377	Valve - check	1
11	501376	Valve - overload protection	1
10	501246	Blanking end	1
9	501245	Blanking plug	7
8	501244	Bleeding screw	1
7	501243	Orifice Ø0,5	2
6	501242	Valve - check	2
5	501241	Housing	1
4	501235	Valve - counter balance	1
3	500601	Seal - flange	1
2	500600	Seal - flange	1
1	500412	Hex. socket set screw	1
POS	PARTNUMBER	PARTNAME	QT

Static Pulverizer	<i>Page</i>	10	<i>of</i>	16
	<i>Date</i>	August 2014		
	<i>Product type</i>	DSP-60 Extreme		
Counter balance valve	<i>Number</i>	501235-00		

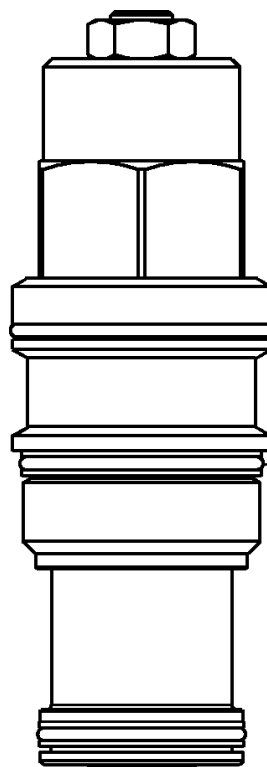

Sealset 504114

Static Pulverizer	Page	11	of	16
	Date	August 2014		
	Product type	DSP-60 Extreme		
Overload protection valve	Number	501376-00		

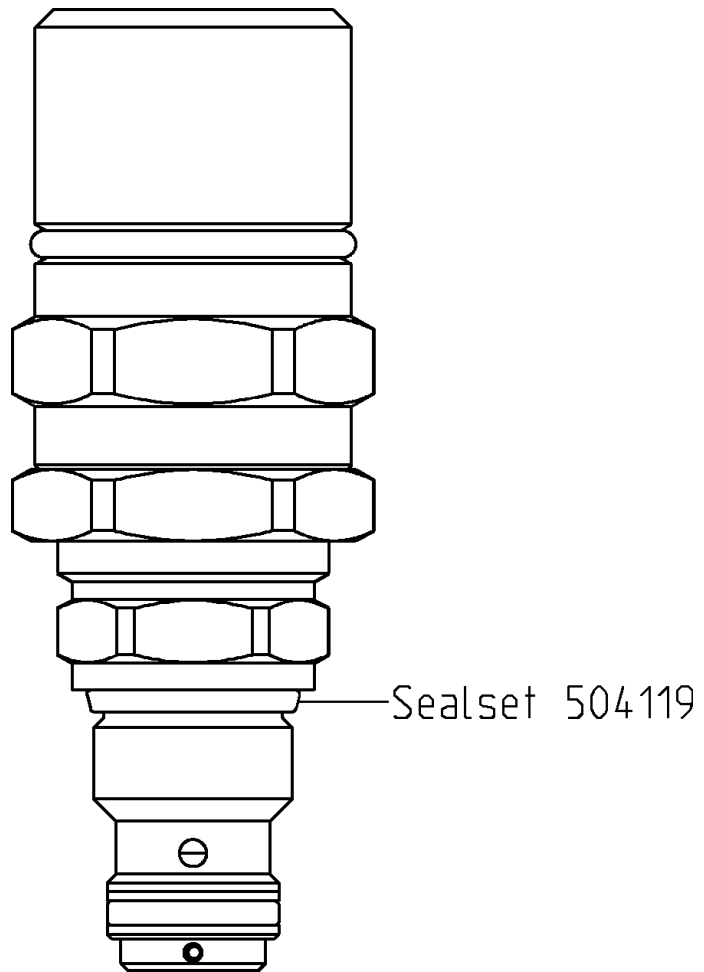

Static Pulverizer	Page	12	of	16
	Date	August 2014		
	Product type	DSP-60 Extreme		
Check valve	Number	501377-00		

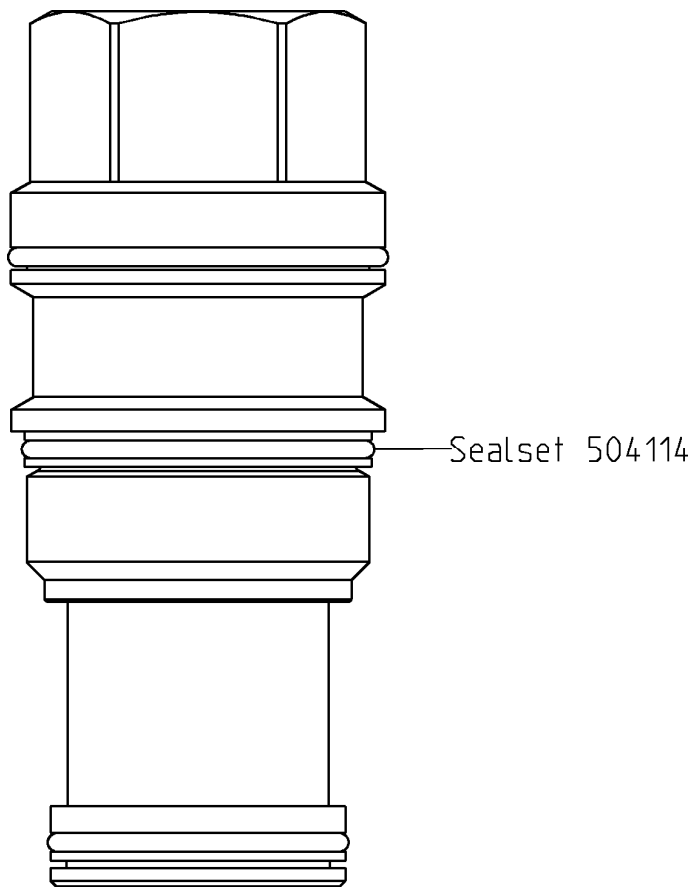

Static Pulverizer	Page	13	of	16
	Date	August 2014		
	Product type	DSP-60 Extreme		
Check valve	Number	501378-00		

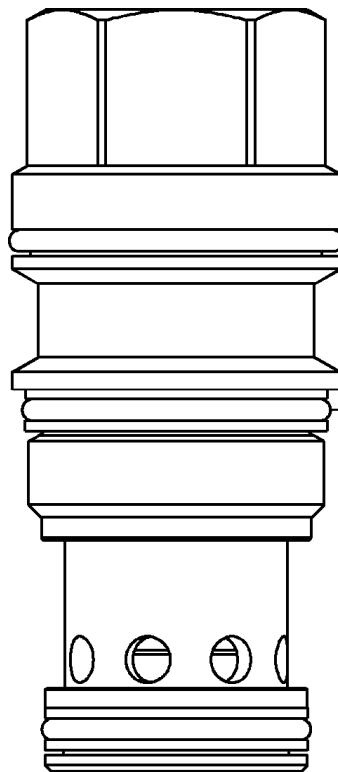

Sealset 504057

Static Pulverizer	Page	14	of	16
	Date	August 2014		
	Product type	DSP-60 Extreme		
Check valve	Number	502117-01		

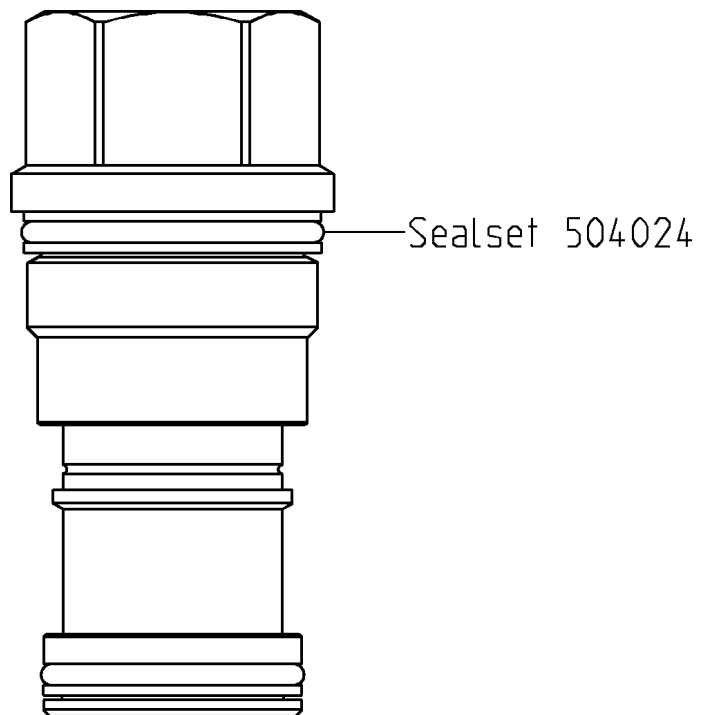

Static Pulverizer	Page	15	of	16
	Date	August 2014		
	Product type	DSP-60 Extreme		
Additional parts	Number	n.a.		

Chemical lock

195050158	Cyberbond TT62 Pumpgel	1
506018	Loctite 480 Flacon 20 gr	1
506017	Loctite 638 Flacon 50 ml	1
506016	Loctite 270 Flacon 50 ml	1
PARTNUMBER	PARTNAME	QT

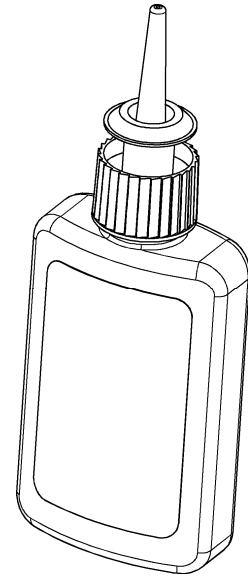

MAG welding wire

- for hard facing cutting blades
- 48-52 HRc

501237	Welding wire MAG; 1.8425, coil 15kg	1
PARTNUMBER	PARTNAME	QT

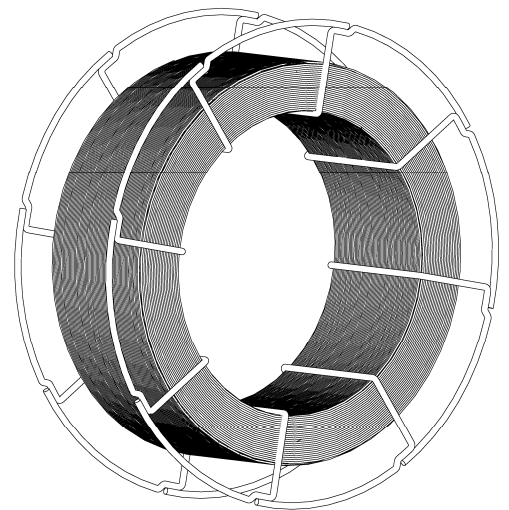

Welding electrodes

- for hard facing cutting blades
- 48-52 HRc

501238	Weld. electr.:1.8425, Ø 2,5mm, box 5kg	1
PARTNUMBER	PARTNAME	QT

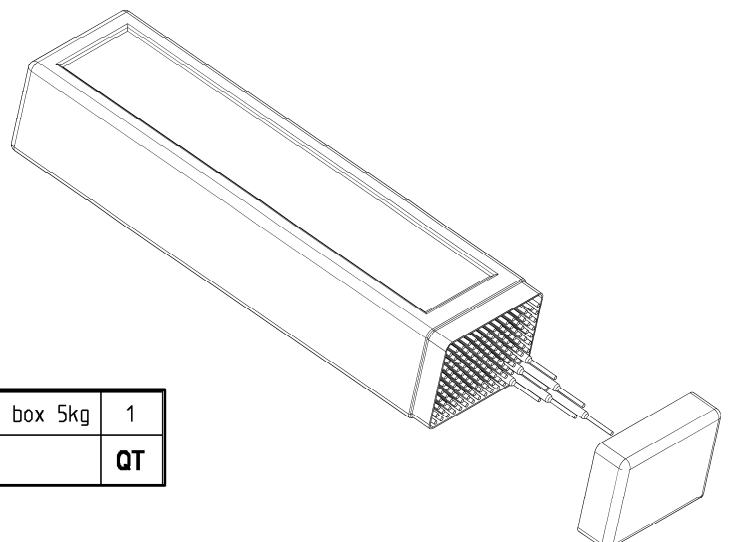

Static Pulverizer	Page	16	of	16
	Date	August 2014		
	Product type	DSP-60 Extreme		
Instructions	Number	n.a.		

Mounting instructions for Cyberbound TT 62

This instruction shall guarantee that all hydraulic fittings and cartridges will be mounted and glued in correctly.

Procedure:

Clean and degrease thoroughly all components with a special cleaner for anarobic adhesives (e.g. Loctite cleaner 7063) or acetone.

Apply on the outside thread only a bead of Cyberbond TT62 pump gel to approx. 2/3 of the girth of the second thread for fittings up to a diameter of 20mm or to the entire girth for fittings with a diameter larger than 20mm.



Cyberbound
TT 62



Clean from adhesive residues pressed out from the bore hole after fitting.

ATTENTION. The sealings shall be free of adhesive residues!

Tighten fittings with given fastening torques.

Standard torque values for bolts (when not indicated)

Thread size	Torque (Nm) for quality		
	8.8	10.9	12.9
M8	22,5	32,4	38,7
M10	45,0	63,0	75,6
M12	77,4	109,0	131,0
M16	194,0	270,0	324,0
M20	369,0	522,0	630,0
M24	639,0	900,0	1080,0
M27	945,0	1305,0	1575,0
M30	1260,0	1800,0	2160,0



DEMAREC AND KINSHOFER WORLDWIDE

Netherlands:

Demarec

Demolition and Recycling Equipment BV

Den Hoek 10

5845 EL St. Anthonis

Netherlands

TEL. +31 (0) 485 442300

FAX +31 (0) 485 442120

Email:

info@demarec.com

United Kingdom:

Kinshofer UK Ltd.

4 Milton Industrial Court,

Horsfield Way, Bredbury

Stockport, Cheshire, SK6 2TA

United Kingdom

TEL. +44 (0) 161 - 406 7046

FAX +44 (0) 161 - 406 7014

Email:

sales@kinshofer.co.uk

France:

Kinshofer France S.A.R.L.

B.P. 20100

67213 Obernai Cedex

France

TEL. +33 (0) 388 39 55 00

FAX +33 (0) 388 79 06 75

Email:

info@kinshofer.fr

Czech Republic:

Kinshofer CZ s.r.o.

Cs. Legii 568

37810 Ceske Velenice

Czech Republic

TEL. +420 384 - 795 110

FAX +420 384 - 795 120

Headquarters:

Germany:

Kinshofer GmbH

Hauptstrasse 76

83666 Waakirchen

Germany

TEL. +49 (0) 8021 - 88 99 0

FAX +49 (0) 8021 - 88 99 37

Email:

info@kinshofer.com

North America:

Kinshofer North America

5040 Mainway Drive, Unit 11

Burlington, ON L7L 7G5

Canada

TEL. +1 (905) 335 2856

FAX +1 (905) 335 4529

Toll Free in Canada and USA:

TEL. 1-800-268-9525

Email:

sales-northamerica@kinshofer.com

Finland:

Kinshofer Aponox Oy

Terminaalitie 10

13430 Hämeenlinna

Finland

TEL. +358 (0)75 7540 200

FAX +358 (0)75 7540 210

Beijing:

Darda Kinshofer

Construction Machinery Co. Ltd.

Unit #306, Landmark Tower 2

8 Dongsanhuan Road

Beijing 100004

China

TEL. +86 (10) 6590 6422

FAX +86 (10) 6590 6423

Email:

info@darda.com.cn