

Parts book

Product type
DRG-45-DN-x-x-x Serie 4



Den Hoek 10
5845 EL St. Anthonis
the Netherlands
Telephone +31 (0)485 442300
Fax +31 (0)485 442120

info@demarec.com
www.demarec.com



*Copyright Demolition and Recycling Equipment BV
All rights strictly reserved.
Reproductions to third parties in any form whatever is not permitted
without written authority from the proprietor*

Sorting Grab	Page	1	of	14
	Date	October 2009		
	Product type	DRG-45-DN-D-D-C		
Grapple GP	Number	D50HD140ABA5 400443-02		

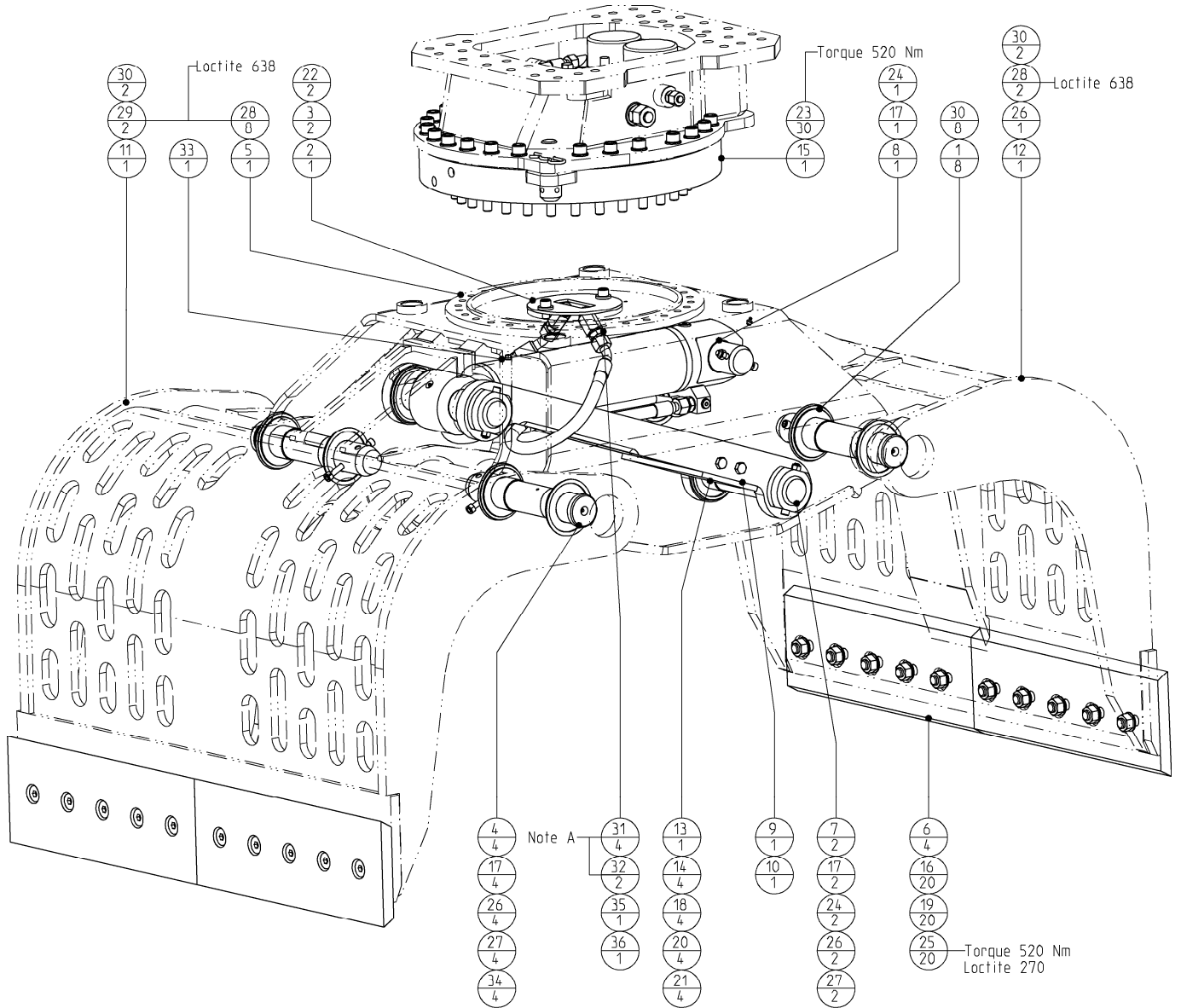

- Note A
- # Degrease threads with brake cleaner.
 - # Rub in- and outside threads in with Cyberbound TT62 by using a brush.
 - # Clean seal from plug during screwing in.
 - # A drying time from the glue of at least 1 hour needs to be respected before it has any contact with oil.

Sorting Grab	Page	2	of	14
	Date	October 2009		
	Product type	DRG-45-DN-D-D-C		
Grapple GP	Number	D50HD140ABA5 400443-02		

				20	500069	Washer spring	4
				19	500056	Washer HV	20
				18	500031	Nut Hexagon self-locking	4
				17	500030	Nut Hexagon self-locking	7
36	500846-04	Hydr. hose asm. 5/8"SAE100R10	1	16	500007	Nut Hexagon	20
35	500846-03	Hydr. hose asm. 5/8"SAE100R10	1	15	401355	Rotatorhead GP	1
34	506003	Hex. socket head cap screw	4	14	401215	Bushing	4
33	502455	Cylinder GP	1	13	401212	Linkage protection asm.	1
32	500741	Sleeve	2	12	400590	Shell asm. LH machined	1
31	500694	Male stud coupling	4	11	400588	Shell asm. RH machined	1
30	500624	Seal	12	10	400586	Parallel-Linkage asm. RH	1
29	500588	Bushing	2	9	400585	Parallel-Linkage asm. LH	1
28	500584	Bushing	10	8	400578	Pin	1
27	500561	Adapter-extension	6	7	400577	Pin	2
26	500560	Grease - nipple	7	6	400441	Bolt on cutting edge	4
25	500383	Flat countersunk head cap screws	20	5	400412	Housing asm. machined	1
24	500303	Hex. socket head cap screw	3	4	400131	Pin	4
23	500302	Hex. socket head cap screw	30	3	400068	Bushing	2
22	500258	Hex. socket head cap screw	2	2	400067	Mounting flange	1
21	500148	Bolts Hexagon	4	1	400041	Spacer	8
				POS	PARTNUMBER	PARTNAME	QT

Sorting Grab	Page	3	of	14
	Date	October 2009		
	Product type	DRG-45-DN-S-D-C		
Grapple GP	Number	D50HD140ABB5 403113-00		

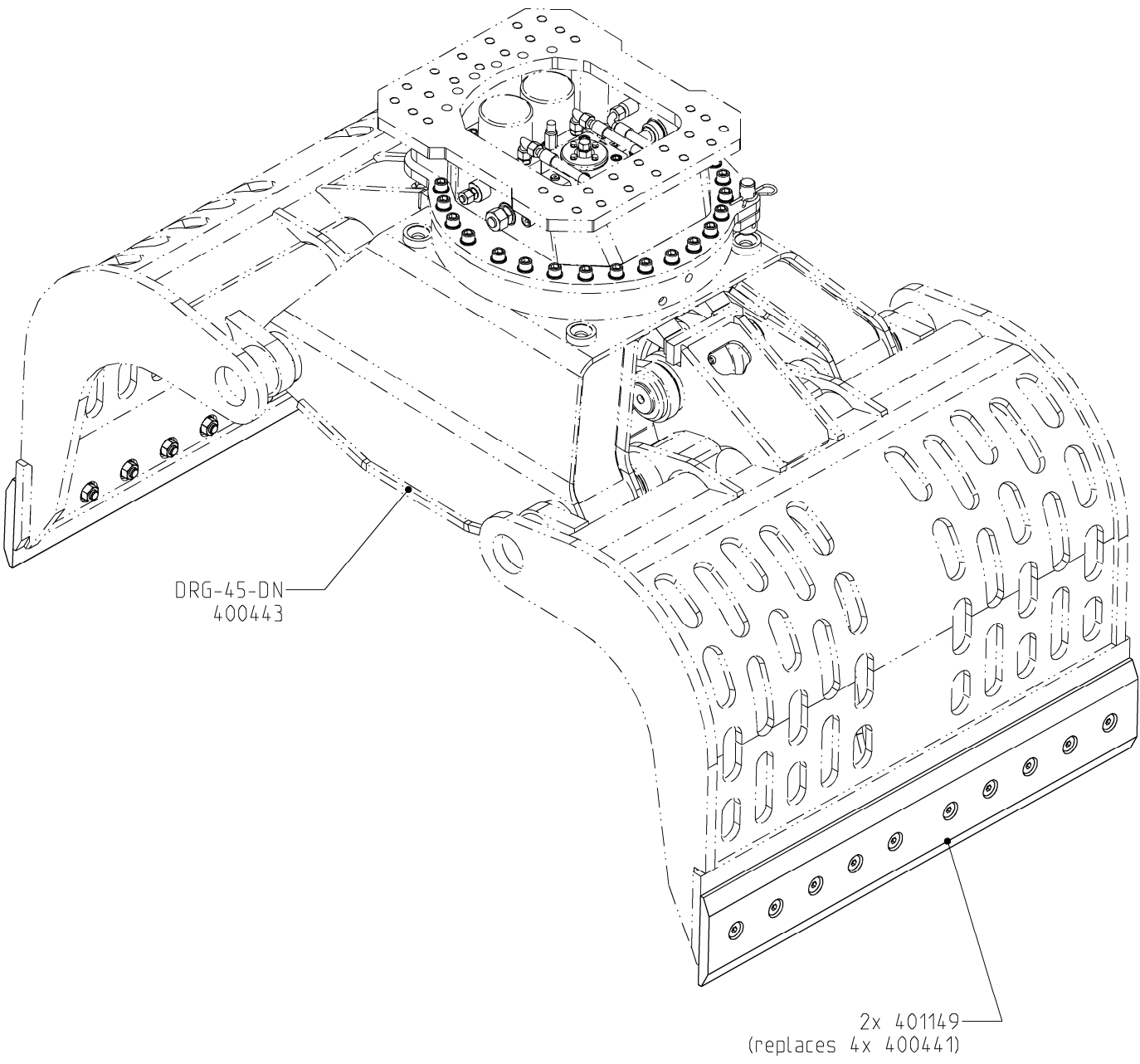

Sorting Grab	Page	4	of	14
	Date	October 2009		
	Product type	DRG-45		
Rotatorhead GP	Number	401355-09		

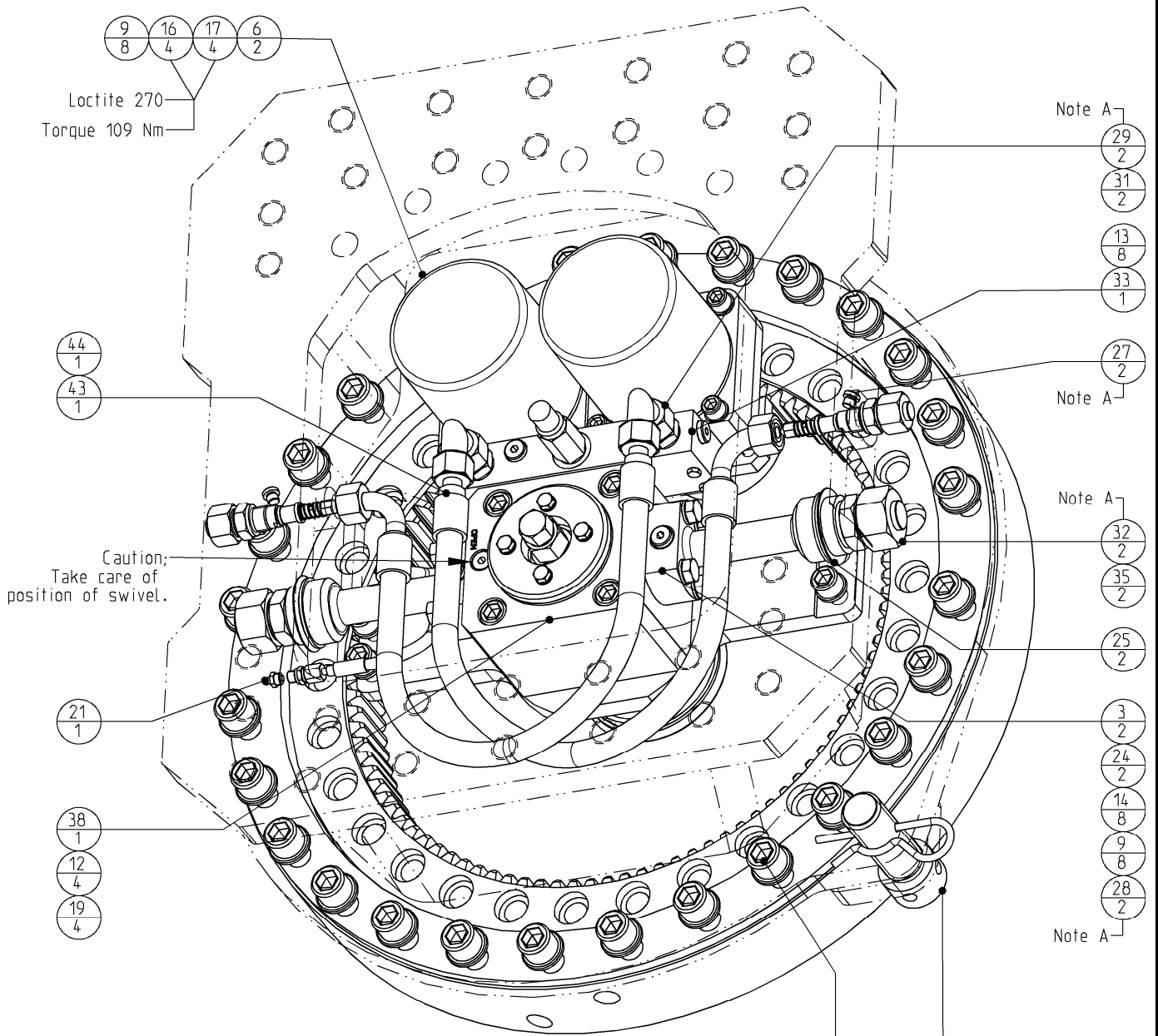

NOTES
 # Take care of position of swivel.
 # Use Loctite 270 for motor bolts.
 # Mount slewing ring bolts with torque 520 Nm

Note A
 # Degrease threads with brake cleaner.
 # Rub in- and outside threads in with Cyberbound TT62 by using a brush.
 # Clean seal from plug during screwing in.
 # A drying time from the glue of at least 1 hour needs to be respected before it has any contact with oil.

8/28 20/28 4/1 42/1
 Torque 520 Nm

Sorting Grab	Page	5	of	14
	Date	October 2009		
	Product type	DRG-45		
Rotatorhead GP	Number	401355-09		

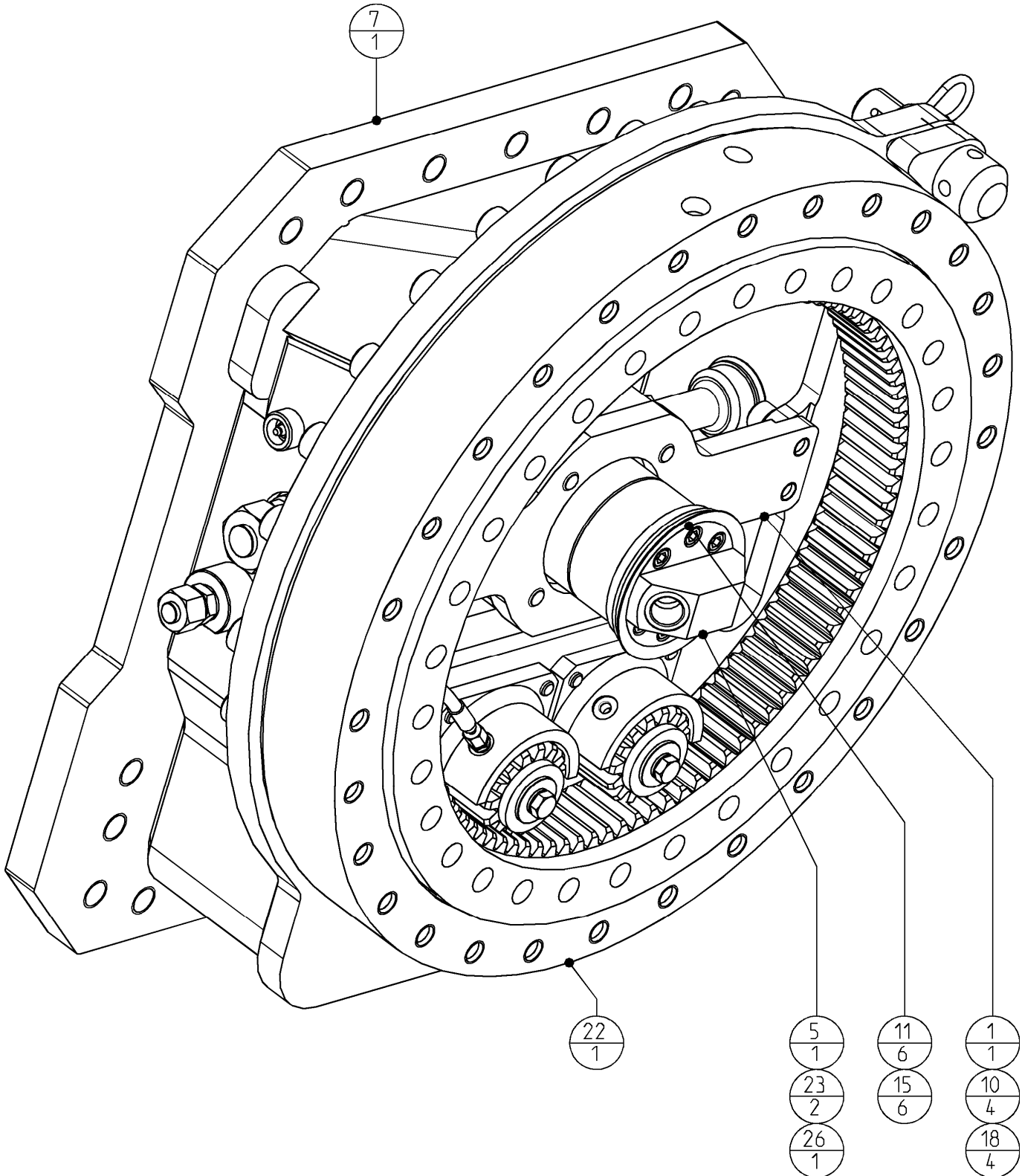

Sorting Grab

Page **6** of **14**

Date **October 2009**

Product type **DRG-45**

Rotatorhead GP

Number **401355-09**

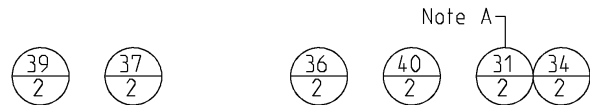
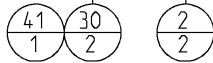
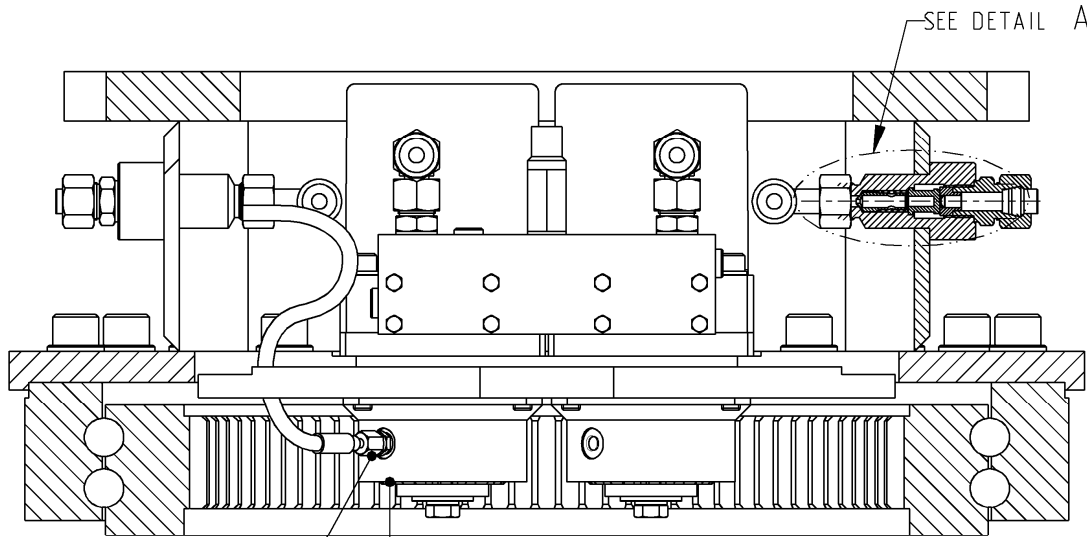

REPLACED FILTER CONSTRUCTION			
POS	PARTNUMBER	PARTNAME	QT
3	502001	Drossel - ring	2
2	502000	Filter	2
1	500693	Male stud coupling	2

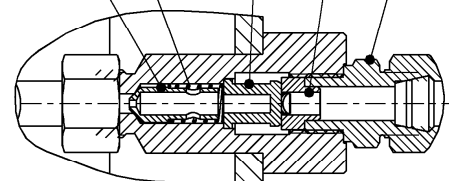

DETAIL A

Note A

- # Degrease threads with brake cleaner.
- # Rub in- and outside threads in with Cyberbound TT62 by using a brush.
- # Clean seal from plug during screwing in.
- # A drying time from the glue of at least 1 hour needs to be respected before it has any contact with oil.

Sorting Grab	<i>Page</i>	7	<i>of</i>	14
	<i>Date</i>	October 2009		
	<i>Product type</i>	DRG-45		
Rotatorhead GP	<i>Number</i>	401355-09		

				23	500600	O-ring	2
				22	500591	Slewing Ring; Internal Gear	1
44	500840_VG02	Hydr. hose asm. 1/2" SAE 100 R2AT	1	21	500560	Grease - nipple	1
43	500840_VG01	Hydr. hose asm. 1/2" SAE 100 R2AT	1	20	500302	Hex. socket head cap screw	28
42	500504-3	Locking pin (hair-pin)	1	19	500268	Hex. socket head cap screw	4
41	296012429_VG01	Hydr. hose asm. 3/16" SAE 100R1AT	1	18	500258	Hex. socket head cap screw	4
40	773058645	Drossel - ring	2	17	500255	Hex. socket head cap screw	4
39	273058601	Cone - valve + restriction	2	16	500253	Hex. socket head cap screw	4
38	207058287	Swivel GP	1	15	500241	Hex. socket head cap screw	6
37	165050749	Spring	2	14	500135	Bolts Hexagon	8
36	502000	Filter	2	13	500099	Bolts Hexagon	8
35	500947	Blanking plug	2	12	500078	Washer spring	4
34	500945	Blanking plug	2	11	500076	Washer spring	6
33	500758	Valve GP	1	10	500069	Washer spring	4
32	500695	Male stud coupling	2	9	500068	Washer spring	16
31	500693	Male stud coupling	4	8	500055	Washer HV	28
30	500690	Male stud coupling	2	7	401356	Rotatorhead asm. machined	1
29	500673	Adjustable male stud elbow	2	6	401201	Motor GP	2
28	500650	Blanking end	2	5	400069	Swivel - flange	1
27	500649	Blanking end	2	4	400066	Lock - pin	1
26	500623	Seal	1	3	400065	Hydraulic flange - pipe	2
25	500621	Seal	2	2	400063	Cap - Pinion	2
24	500601	O-ring	2	1	400062	Plate - base swivel	1
				POS	PARTNUMBER	PARTNAME	QT

Sorting Grab	Page	8	of	14
	Date	October 2009		
	Product type	DRG-45		
Hydraulic motor GP	Number	401201-00		

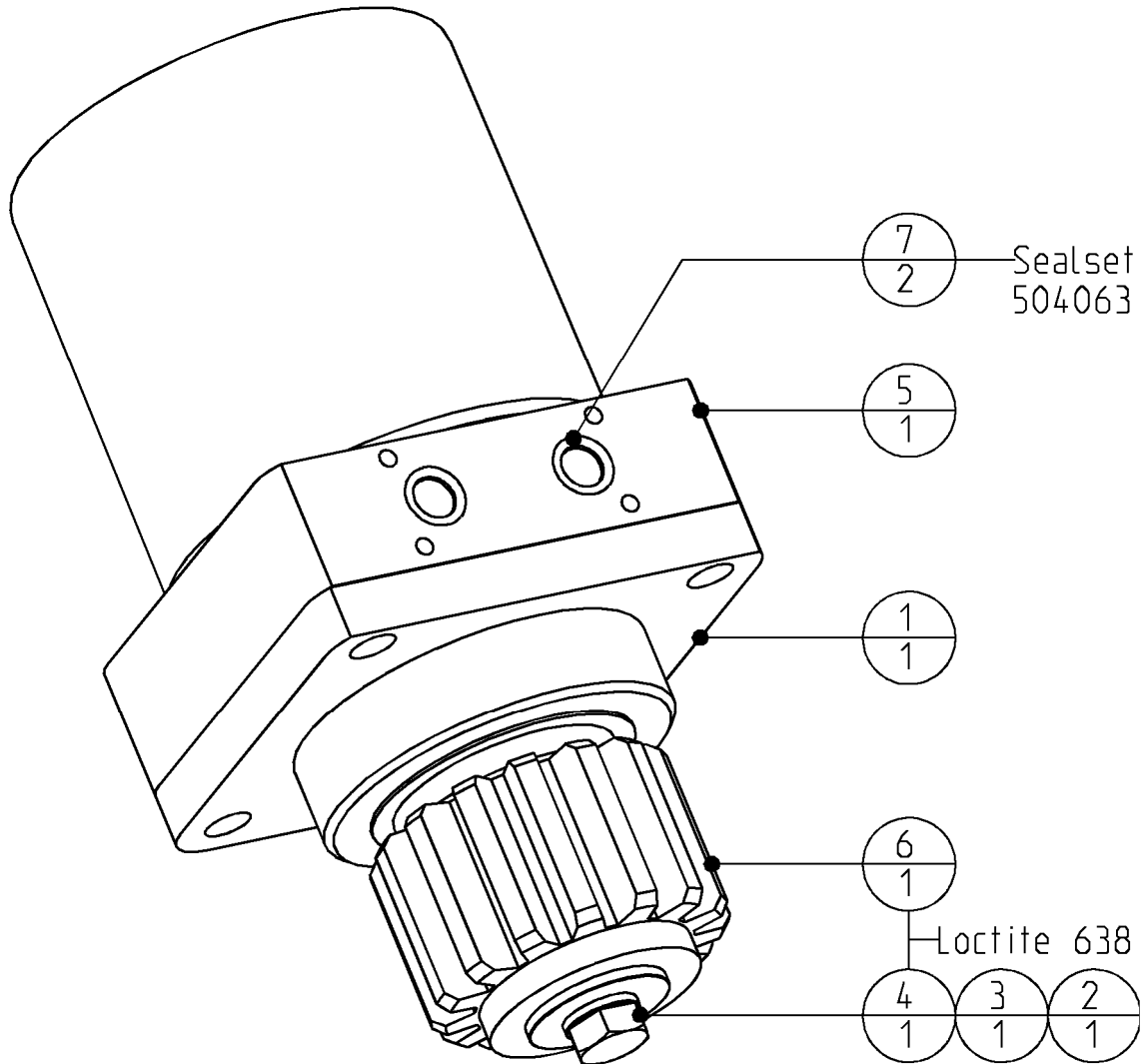

7	504070	O-ring	2
6	500851	Pinion	1
5	500763	Hydro-motor	1
4	500131	Bolts Hexagon	1
3	500068	Washer spring	1
2	500062	Washer con	1
1	400593	Motor-flange	1
POS	PARTNUMBER	PARTNAME	QT

Sorting Grab	Page	9	of	14
	Date	October 2009		
	Product type	DRG-45		
Valve GP	Number	500758-03		

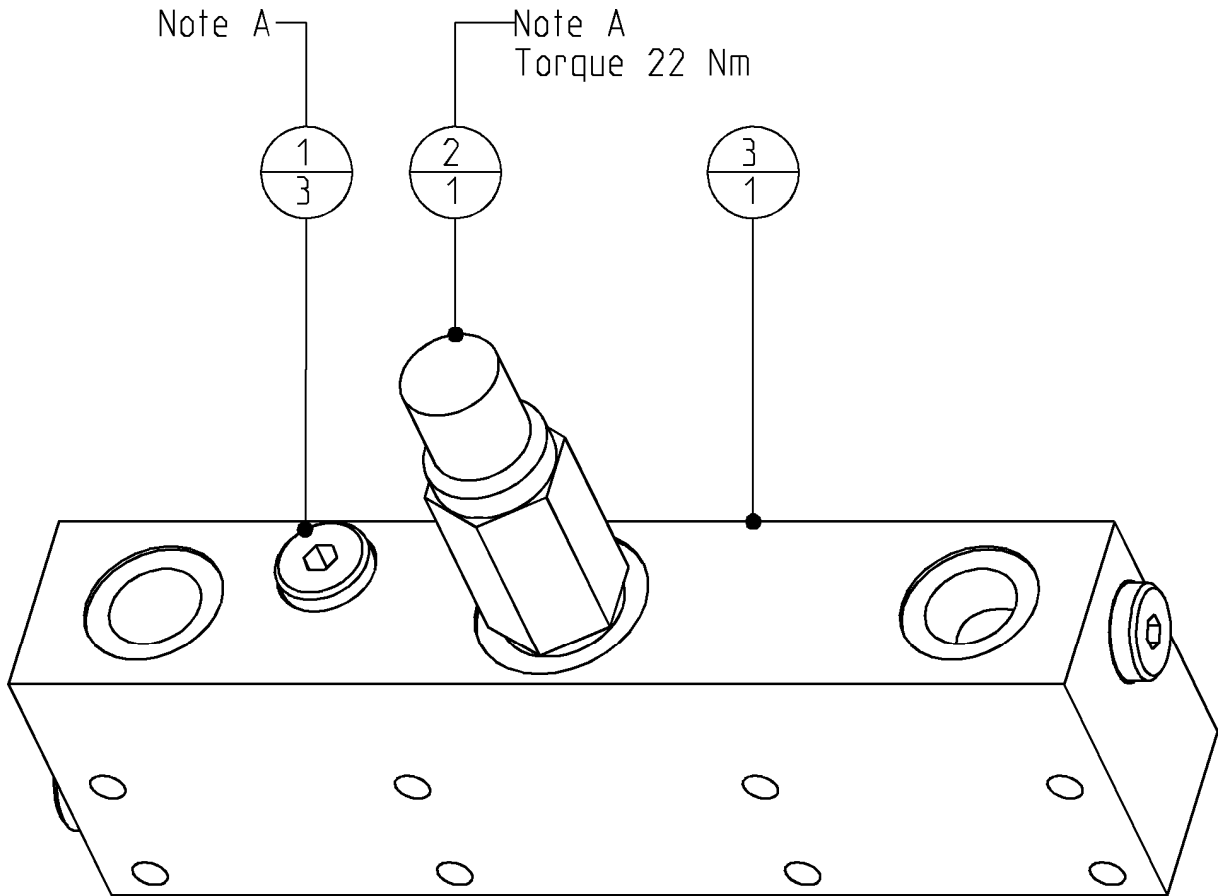

Note A

- # Degrease threads with brake cleaner.
- # Rub in- and outside threads in with Cyberbound TT62 by using a brush.
- # Clean seal from plug during screwing in.
- # A drying time from the glue of at least 1 hour needs to be respected before it has any contact with oil.

3	500759	Baseplate	1
2	500757	cross-over relieve valve	1
1	500650	Blanking end	3
POS	PARTNUMBER	PARTNAME	QT

Sorting Grab	Page	10	of	14
	Date	October 2009		
	Product type	DRG-45		
Swivel GP	Number	207058287-C		

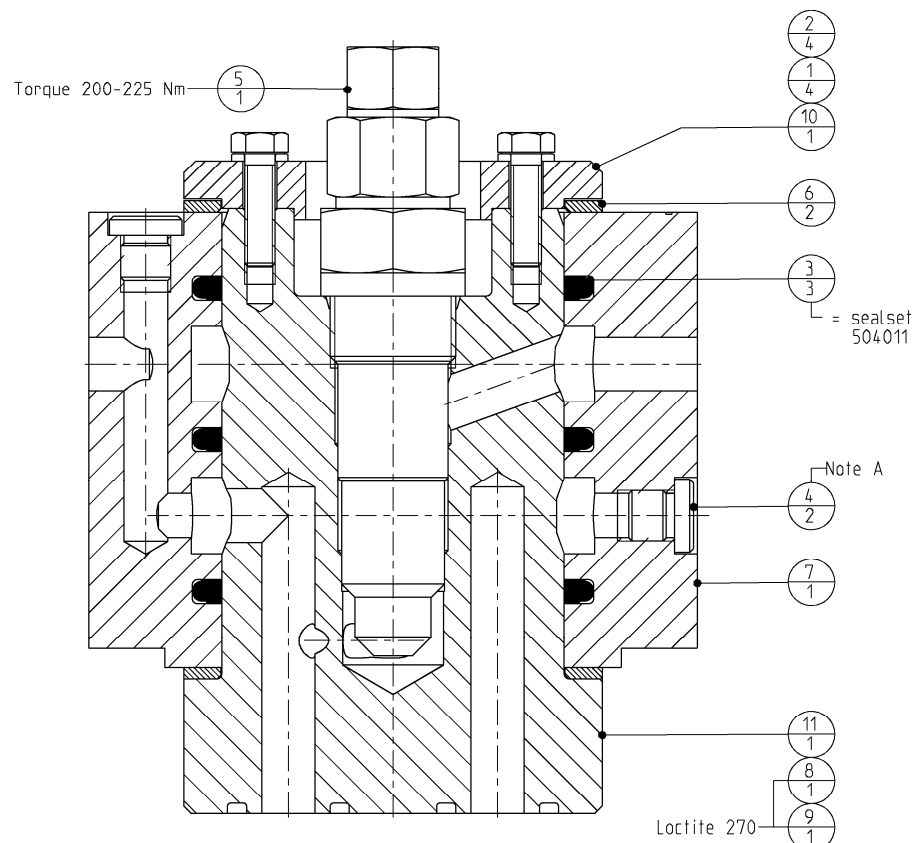
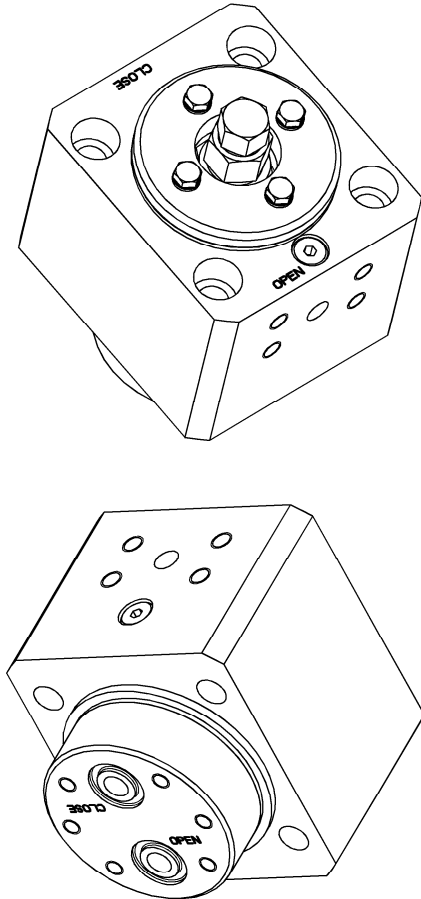

Note A
 # Degrease threads with brake cleaner.
 # Rub in- and outside threads in with Cyberbound TT62 by using a brush.
 # Clean seal from plug during screwing in.
 # A drying time from the glue of at least 1 hour needs to be respected before it has any contact with oil.

11	244058288	Stator	1
10	235058295	Cover	1
9	502124	Hex.socket plug-tapped	1
8	502123	Hex.socket plug-tapped	1
7	500833	Swivel - housing	1
6	500832	Axial ring	2
5	500751	Overcentre valve	1
4	500650	Blanking end	2
3	500630	Seal - Roto Glyd Ring with Rotolock	3
2	500105	Bolts Hexagon	4
1	500066	Washer spring	4
POS	PARTNUMBER	PARTNAME	QT

Sorting Grab	Page	11	of	14
	Date	October 2009		
	Product type	DRG-45		
Cylinder GP	Number	502455-01		

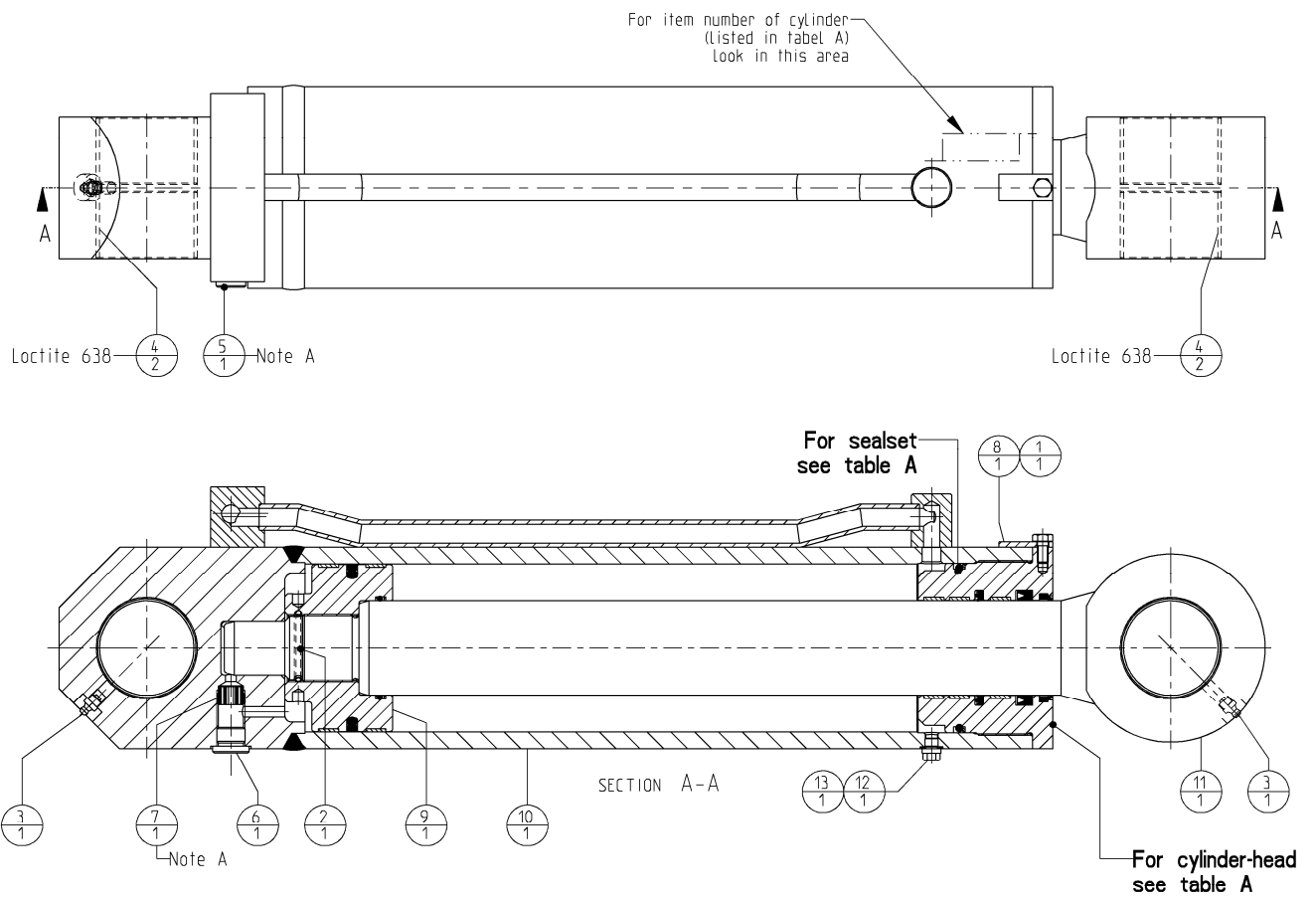

sealset and cylinderhead			
Item no. (on cylinder)	Sealset (service only)	Cylinder-head	Remark
502455 - 00 and up	504093	502451	
500895 - 00 and up	504093	500881	502451 replaces 500881

table A

Note A

- # Degrease threads with brake cleaner.
- # Rub in- and outside threads in with Cyberbound TT62 by using a brush.
- # Clean seal from plug during screwing in.
- # A drying time from the glue of at least 1 hour needs to be respected before it has any contact with oil.

Sorting Grab	<i>Page</i>	12	<i>of</i>	14
	<i>Date</i>	October 2009		
	<i>Product type</i>	DRG-45		
Cylinder GP	<i>Number</i>	502455-01		

13	504027	Seal	1
12	503513	Blanking screw	1
11	500899	Cylinder - rod asm.	1
10	500896	Cylinder - house asm.	1
9	500882	Piston	1
8	500859	Lockplate	1
7	500752	Non-return valve	1
6	500652	Blanking end	1
5	500651	Blanking end	1
4	500584	Bushing	4
3	500560	Grease - nipple	2
2	500522	Springtype straight pin	1
1	500102	Bolts Hexagon	1
POS	PARTNUMBER	PARTNAME	QT

Sorting Grab	Page	13	of	14
	Date	October 2009		
	Product type	DRG-45		
Sealset	Number	504093-01		

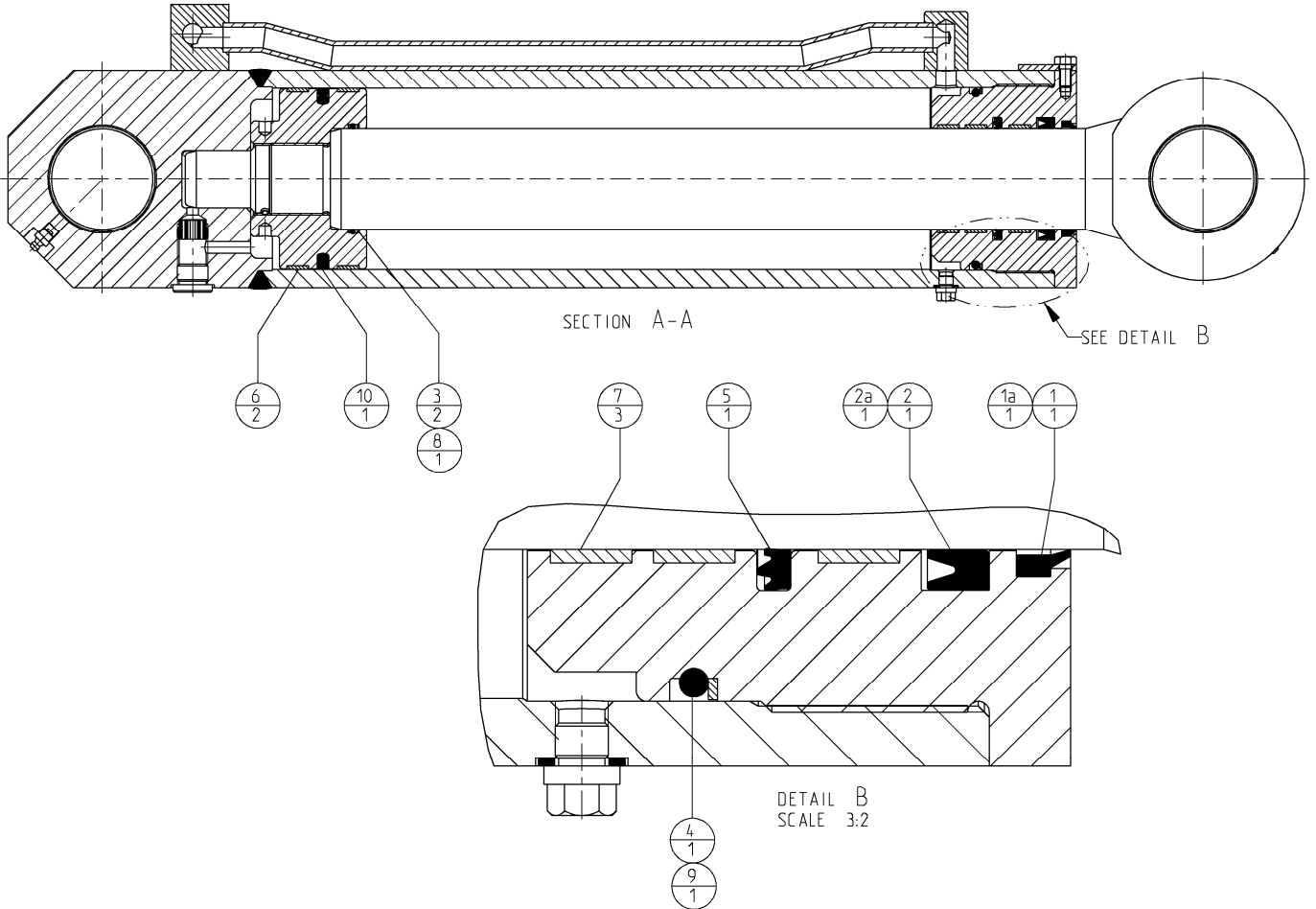

2a	RSK300700	Turcon Stepseal 2K	1
1a	UWRP707806	Scraper UWR-derivative	1
POS	PARTNUMBER	PARTNAME	QT
Additional seals for service			
10	PT0401250	Turcon Glydring T	1
9	ORAR00349	O-ring	1
8	ORAR00232	O-ring	1
7	GR73A0700	Bearing Luytex	3
6	GP7301250	Bearing Luytex	2
5	BU007100656	Rod seal GP	1
4	BU4301174	Back-up ring	1
3	BU2700700	Back-up ring	2
2	B37085P6000	U-Cup	1
1	504089	Scraper	1
POS	PARTNUMBER	PARTNAME	QT

Multi Quick Processor	<i>Page</i>	14	<i>of</i>	14
	<i>Date</i>	October 2009		
	<i>Product type</i>	DRG-45		
Chemical lock	<i>Number</i>	n.a.		

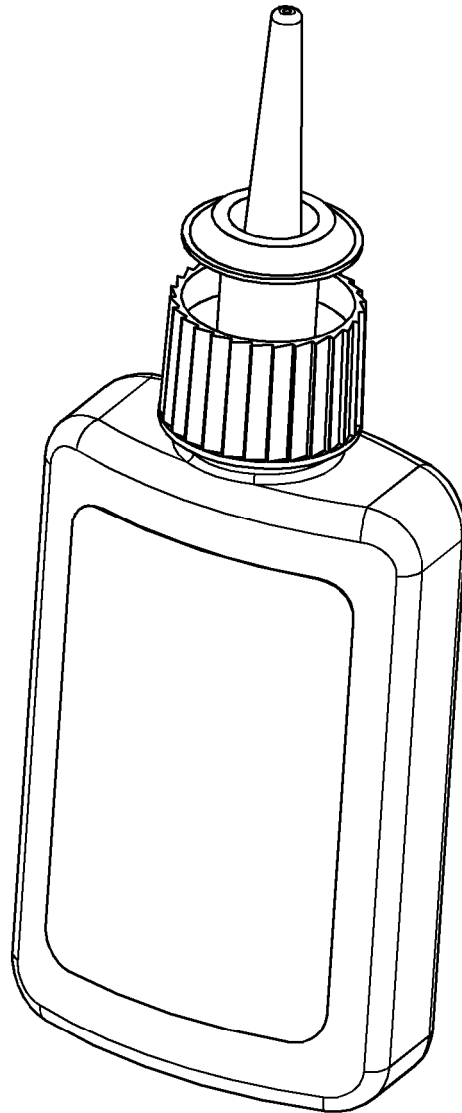

195050158	Cyberbond TT62 Pumpgel	1
506017	Loctite 638 Flacon 50 ml	1
506016	Loctite 270 Flacon 50 ml	1
PARTNUMBER	PARTNAME	QT